

# EMP (Electromagnetic Pulse) Protection Power Filters



With the increasing need to protect equipment housed within a shielded area from the damaging and disrupting effects of electromagnetic pulses and signals, as well as providing protection against surges produced from solar flares, nuclear weapons and lightning strikes, our uniquely designed range of modular filters ensure equipment is suitably protected at all times.

EEP Filters design and manufacture a complete range of 2-Line/SP&N and 4-Line/TP&N EMP/HEMP power line filters. The standard range is 16A, 32A, 63A, 100A, 250A and 400A supporting facility compliance with the required standards of MIL-STD-188-125, DEF-STAN 59-188 and NATO AECTP-500. Bespoke modular designs are available to service high power cable entries to large buildings up to 1600A and higher. Designs whose insertion loss performance will be compliant with NATO TEMPEST standard SDIP-29, and the most stringent GCHQ and NSA TEMPEST specifications can also be offered.

The circuit designs of the filters are individual discrete lines for full performance in both common and differential modes. The performance is maintained under all current loading conditions across the full frequency spectrum and the discrete line construction makes the filters fully electrically versatile in respect of connecting to the power supply. The mechanical design of the filters allows them to be installed either outside or inside of an EMP/HEMP protected area. The surge arrestors fitted to the filters makes them suitable for electrical circuits also protecting against the effects of secondary lightning.

## Standard Filter Range

<b>16A</b>	EEPF-16-2-PL	2 line, 240VL-L, 50/60Hz HEMP Passive EMI Filters
<b>32A</b>	EEPF-32-2-PL	2 line, 240VL-L, 50/60Hz HEMP Passive EMI Filters
<b>32A</b>	EEPF-32-4-PL	4 line, 415VL-L, 50/60Hz HEMP Passive EMI Filters
<b>63A</b>	EEPF-63-4-PL	4 line, 415VL-L, 50/60Hz HEMP Passive EMI Filters
<b>125A</b>	EEPF-125-4-PL	4 line, 415VL-L, 50/60Hz HEMP Passive EMI Filters
<b>200A</b>	EEPF-200-4-PL	4 line, 415VL-L, 50/60Hz HEMP Passive EMI Filters
<b>250A</b>	EEPF-250-4-PL	4 line, 415VL-L, 50/60Hz HEMP Passive EMI Filters
<b>400A*</b>	EEPF-400-4-PL	4 line, 415VL-L, 50/60Hz HEMP Passive EMI Filters



400A HEMP Filter

\*400A filters can be installed parallel to provide up to 1600A combinations.

# EMP (Electromagnetic Pulse) Protection Power Filters

**HEMP Performance:** Standard range designed in accordance with IEC 61000-4-24, severity levels 1 & 2. Tailored performance available upon request.

**Insertion Loss Performance (50 Ohm asymmetric, IEC CISPR17: 2011):** 80dB from 10MHz to 1GHz as standard. Tailored performance available upon request.

**Configuration:** "C" configuration as standard. In line/rear cable terminations. Other configurations available upon request.



Installed Filter Array

**Colour:** RAL 9016 Traffic White, full gloss. Other colours and textures can be accommodated upon request.

**Labelling:** Self-adhesive industrial vinyl (logo labelling with serial numbering and ratings). Earthing, termination phase markers and input/output labels are to be fitted as standard.

## Each Filter Comprises of the Following:

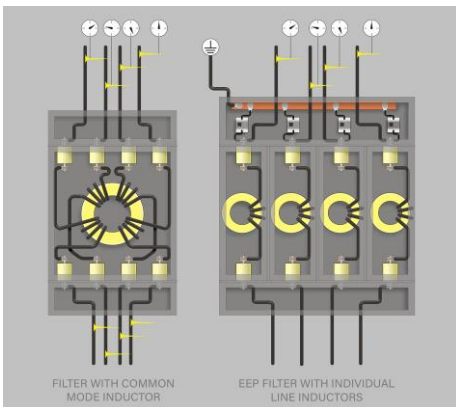

- HEMP Filtered Lines (2 no. for single phase and neutral circuits)
- 1 no. \*Cable Entry Enclosure
- 1 no. \*Cable Exit Enclosure

\*Bespoke filters manufactured to specific end user requirements regarding performance levels, dimensions and design are available upon request.

## Testing & Certification:

All our Filters undergo extensive testing and as such are issued along with the following certification:

- A general electrical safety certificate will be issued per unit/batch.
- This includes an Insertion Loss Test Certificate to 4GHz as standard.

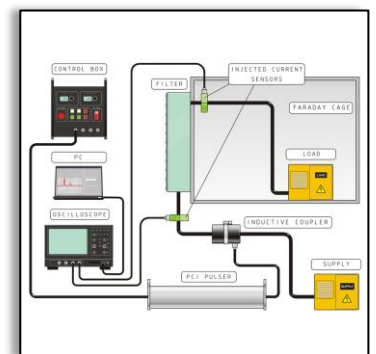

# EMP (Electromagnetic Pulse) Protection Power Filters

## Outline, Dimensions, Mechanical Details & Mass:

### 2 Line Power Filter

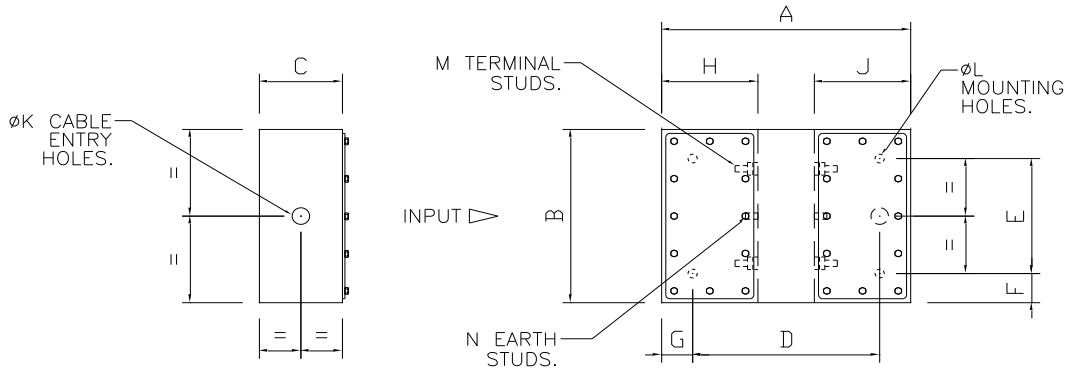

### 4 Line Power Filter

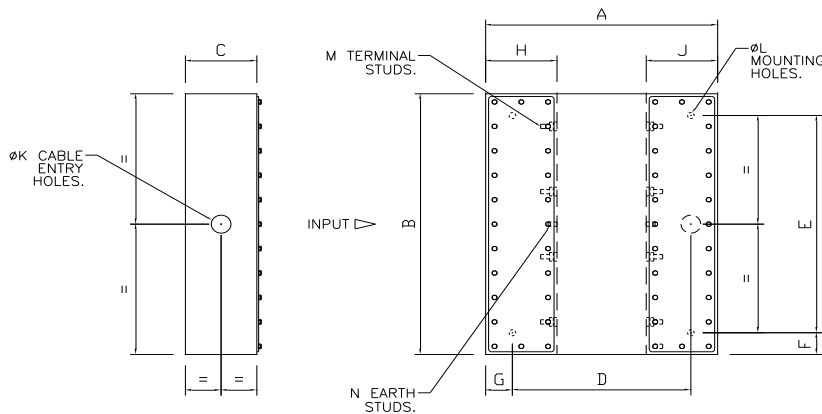

## Dimensions (mm):

	A	B	C	D	E	F	G	H	J	K	L	M	N	Mass Approx.
16A	393	240	138.5	323	150	45	35	120.75	120.75	21	11	M8	M8	8kg
32A 2L	393	240	138.5	323	150	45	35	120.75	120.75	21	11	M8	M8	8Kg
32A 4L	539	400	120	439	240	20	50	121	121	21	11	M8	M8	20kg
63A	390	480	120	340	440	20	25	120	120	33	11	M8	M8	55Kg
125A	450	480	120	400	440	20	25	150	150	52	11	M12	M12	65Kg
200A	700	620	175	640	560	30	30	200	200	52	17	M12	M12	80Kg
250A	700	620	175	640	560	30	30	200	200	52	17	M12	M12	80Kg
400A	1000	770	250	860	630	70	70	300	300	64	17	M20	M20	100Kg

# EMP (Electromagnetic Pulse) Protection Power Filters

## Injected Pulse Characteristics for HEMP Power Line Filters\*

Class of POE	Type of Injection	Peak Short Circuit Current (A)	Peak Response Time (A)	Rise Time	FWHM (s) - Full Width at Half Maximum Amplitude
Short Pulse	Common Mode	5,000	< 10A (< 50A 32 Amp, 2 Line)	< 20 ns	50 $\mu$ s – 55 $\mu$ s
Short Pulse	Wire to Ground	2,500	< 10A (< 50A 32 Amp, 2 Line)	< 20 ns	50 $\mu$ s – 55 $\mu$ s
Intermediate Pulse	Common Mode	250	No Damage or Performance Degradation	< 1.5 $\mu$ s	3 ms – 5 ms
Intermediate Pulse	Wire to Ground	250	No Damage or Performance Degradation	< 1.5 $\mu$ s	3 ms – 5 ms

\*EEP Filters can offer an equivalent range of Control, and Signal Line HEMP filters upon request.

## Insertion Loss

The higher the insertion loss the greater the filter performance. Insertion loss, generally expressed in Decibels, is the ratio of the power received before the insertion of the EMC Filter to the power received after the insertion of the EMC Filter. The insertion loss is measured in the frequency domain and for EMP applications the spectrum is usually between 50Hz and 1GHz, however frequencies outside of this spectrum can be tested.

Insertion loss testing is generally measured in the asymmetric (Common) mode in a balanced 50 Ohm impedance system. The main specifications for filter testing are BS613 and MIL. STD. 220A. If the filters supplied use toroidal current compensating inductor technology the tests can be conducted without full load current being passed through the filter at the time of tests. This is because current compensating filter inductors do not saturate and therefore the performance does not alter as the load current changes.

The measurements are taken by using a tracking/signal generator and spectrum analyser. The signal sweeps across the frequency range and is passed through the test leads, which are coupled directly, and received by the spectrum analyser. This signal is then 'normalised' to the 0dB.

It must be recognised that insertion loss measurements made in a 50 Ohm system, while giving good guidance and comparative performance figures, may differ from those achieved in practical situations. This is because although mains supplies are assumed to be 50 Ohm as far as RFI is concerned in practice the terminating impedance can be somewhat different.

Insertion Loss into 50 Ohm load as per Mil Std 220									
Frequency (MHz)	0.01	0.1	1	10	100	200	400	800	1000
Insertion Loss (dB)	20	40	65	80	90	90	90	90	100

# EMP (Electromagnetic Pulse) Protection Power Filters



European EMC Products

Product Overview

## Filters for HEMP

When using asymmetric filters, the assumption is made that any radiated RF would couple equally and balance in to all conductors at once. But in real life no two signals are ever identical or perfectly balanced and any imbalance in a system carrying common mode signals can create a voltage difference between the conductors, giving rise to differential signals.

The chance of signals arriving just right for an asymmetric filter to stop them is highly unlikely given atmospheric conditions, propagation of the wave, number of electrons released, distance between power lines, etc. In HEMP applications, the EMP will arrive chaotically and unpredictably at the Points of Entry (POE). Filters should be able to reject symmetric signals. If asymmetric only filtering is used, not only will the signals get through, but these unpredictable signals (some of which could be of very high amperage) could cause an imbalance in the common core of the asymmetric filter which would lead to instantaneous saturation of the core(s) and total loss of protection to any form of electromagnetic energy.

## Conclusion

Symmetric (differential mode) and asymmetric (common mode) signals are different types of signals that may be present in conductors. It is also clear that these may be removed by using symmetric filters.

Asymmetric filters can only remove asymmetric signals. While asymmetric filters are generally physically smaller than the symmetric filters, the use of asymmetric filters must be very carefully evaluated or unwanted differential mode signals may inadvertently pass through the filtering network and compromise overall system performance.

FOR HEMP PROTECTION SINGLE LINE SYMMETRIC FILTERS MUST BE USED

## About Us

Established in 1996, European EMC Products (EEP) are an established British company whose experience and understanding of the science of shielding makes it an ideal partner in whom you can place your trust with confidence. The purpose of installing EEP shielding systems is to protect people and equipment against the threats posed by electromagnetic and radio frequency (RF) interference, radiation, magnetic fields and electromagnetic pulses. Our diverse range of turnkey products and services, including design, project management, testing and consultancy are delivered across multiple sectors to an international client base.

## Quality

European EMC Products Limited are registered to BS EN ISO 9001:2015, Certificate Number FS38901.

Registered Scope: The design, assembly, installation, servicing and testing of RF Shielded Structures and equipment including EMI Shielding, Blast Doors, Gas Tight Doors and specialised mobile Electromagnetic Pulse Protection (EMPP) containers.

Radio Frequency, Magnetic Shielding and Quench systems for MRI (Magnetic Resonance Imaging) scanners.

The design, assembly and installation of Ionising Radiation Protection facilities.

The design, manufacture and installation of LED lighting systems for medical applications.

EEP Filters Limited are registered to BS EN ISO 9001:2015, Certificate Number FS38901.

Registered Scope: The design, manufacture, management of installation and testing of high performance EMC and EMP Power and Data Line Filters.

## Disclaimer

NB: All of the information provided within this datasheet is for reference only. Product specifications are subject to change without notice.